

## B5BX Series

### Air Handler

1.5 - 5.0 Ton Capacity - 50 Cycle

18,000 - 60,000 Btuh (Air Conditioner & Heat Pump)

The B5BX Series of air handlers, when combined with our heat pump or air conditioner, offer a full line of quality, split system heating and cooling equipment.

#### FEATURES and BENEFITS

- **Durable, Attractive Cabinet** — Designed using galvanized steel. The door is also galvanized steel, with a polyester urethane finish. The 950 hour salt spray finish resists corrosion 50% better than comparable units. The plastic drain pan is corrosion-resistant.
- **Multi-poised** — Can be used in horizontal, upflow, downflow and vertical applications.
- **Multi-speed** — Gives flexibility of installation.
- **Ease-of-Service** — Plug-in wire connections and built-in filter rack makes the air handler easy to service.
- **Plug-in Heater Kits** — Available in 5kw - 30 kw (Not for use in 115 Volt units)
- **Circuit Board** — Incorporating blower time delay relay, low voltage terminal strip, and heat-strip sequencing.
- **Air Handler Control Board** — Controls time-sequencing of heat stages with field-selectable sequence timing.
- **Breaker Accessibility** — Breaker accessible from front of unit when heater is applied.
- **No Fasteners on Sides or Back** — Smooth surfaces for ease of installation.
- **Cabinet Insulation** — 1" insulation with an R-value of 4.2 contributes to quiet operation and prevents cabinet sweating in difficult applications.

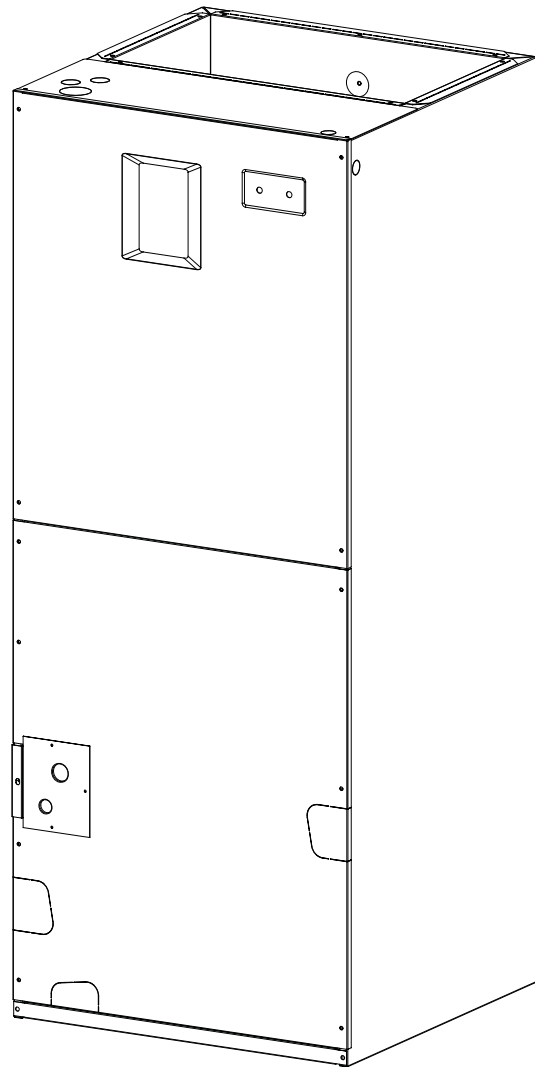

# MODEL IDENTIFICATION CODE - B5BX Air Handler

<b>EX: B5BX-018/024E</b>						
<b>B</b>	<b>5</b>	<b>B</b>	<b>X</b>	<b>-</b>	<b>018/024</b>	<b>E</b>
Air Handler			Multipoise Export		Nominal Capacity	Electrical Code Volts-Phase-Cycle 220/240/1/50
Series						
Standard Blower Motor						
			018/024 = 800 CFM    048 = 1600 CFM 030/036 = 1200 CFM    060 = 2000 CFM 036/042 = 1400 CFM			

## DIMENSIONS

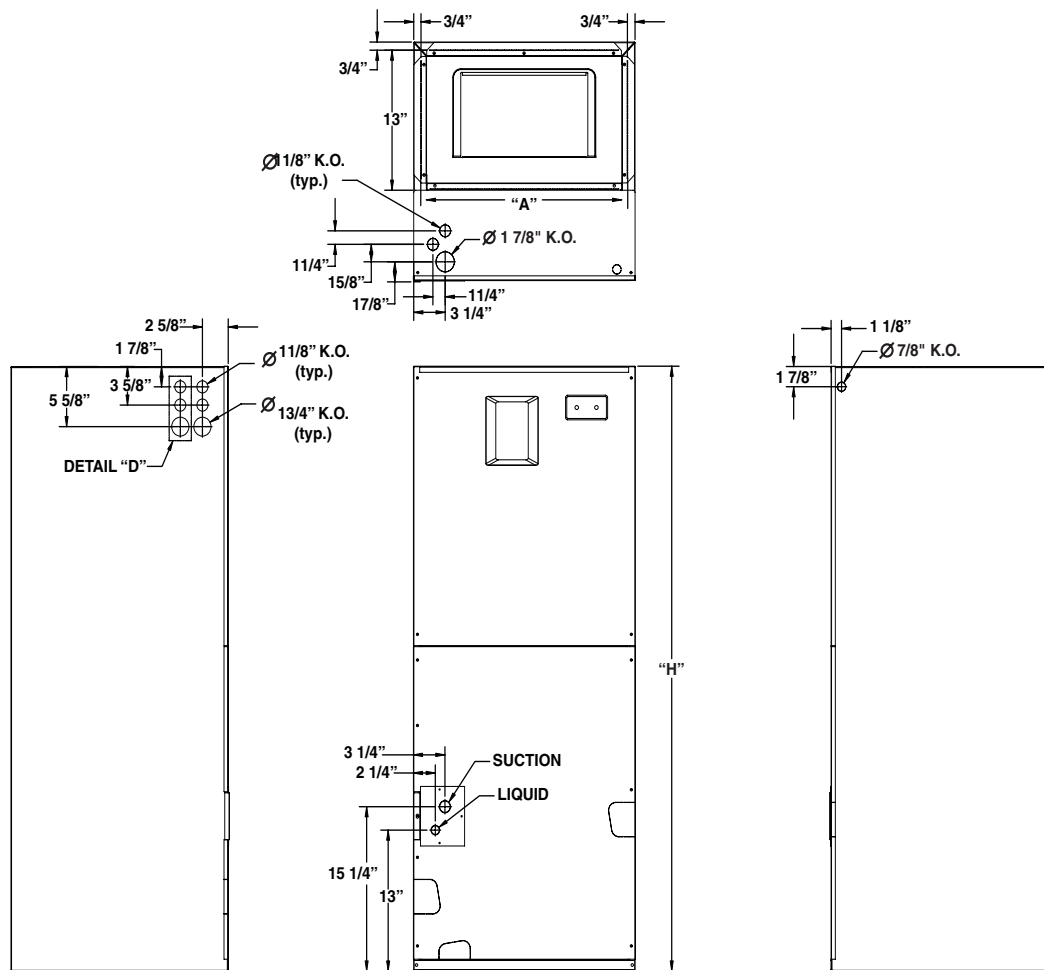

Model	H	W	Refrigerant Connections	
			Suction Dia.	Liquid Dia.
018/024	43 1/2	14 1/4	3/4	3/8
030/036	43 1/2	14 1/4	3/4	3/8
042/048	43 1/2	19 3/4	3/4	3/8
060	49 1/2	19 3/4	7/8	3/8

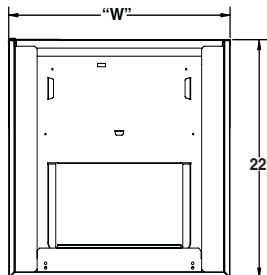

# SPECIFICATIONS - B5BX Air Handler

## 50 Hz

Air Handler B5BX	018/024	030/036	042/048	060
Nominal Cooling Capacity - Btuh (10 SEER H/P)	18,000/ 23,000	28,600/ 34,000	40,000/ 47,000	56,500
Refrigerant Flow Control	Fixed Orifice			
Orifice Size	.051/.060	.063/.067	.075/.080	.093
Maximum Available Auxiliary Heat (kw)	10	10	20	20
Nominal Blower Size (D x W)	10 x 6	10 x 6	10 x 8	10 x 8
(H.P. - Speed - Type)	1/5-3-PSC	1/3-3-PSC	1/3-3-PSC	1/2-3-PSC
Rated External Static Pressure (in. W.C.)	.30	.35	.35	.40
Filter Size (Inches)	12 x 20 x 1	12 x 20 x 1	18 x 20 x 1	18 x 20 x 1
Approximate Shipping Weight (lbs.)	75	85	110	145

## ACCESSORIES - B5BX

Accessory Kit Description	Cabinet Size			Order Number
	A	B	C	
Downflow Adaptor Kit	X			917342
		X		919321
			X	919322
Single Circuit Adaptor Kit		X	X	913874

KW	Approved for Cabinet	Order Number	
		with Circuit Breaker(s)	w/o Circuit Breaker(s)
5	A, B	904407	904406
8	A, B	904409	704408
10	A, B	904412	904411
15	B	904414	N/A
20	B	904416	N/A

## SYSTEM AIR FLOW DATA - B5BX

Model	HP/wheel	Speed	ESP (" H <sub>2</sub> O)	CFM Low	CFM Med	CFM High
018/024	1/5 HP 10 X 6	3	0.1	650	780	910
			0.2	610	740	870
			0.3	540	670	800
			0.4	460	600	720
			0.5	370	510	630
030/036	1/3 HP 10 X 6	3	0.1	890	1160	1310
			0.2	880	1150	1300
			0.3	830	1100	1250
			0.4	790	1060	1210
			0.5	740	1030	1180
042/048	1/3 HP 10 x 8	3	0.1	1060	1380	1560
			0.2	1050	1370	1550
			0.3	1000	1310	1480
			0.4	950	1250	1410
			0.5	910	1200	1290
060	1/2 HP 10 X 8	3	0.1	1790	2050	2260
			0.2	1780	2040	2250
			0.3	1720	1980	2200
			0.4	1670	1920	2130
			0.5	1610	1870	2070

### Notes:

- 1) Airflow is shown in cfm, +/- 5%.
- 2) External static pressure is shown in inches w.c.
- 3) All airflows are measured without filter and with dry coil. For filter velocity of 300 ft./min. subtract .08" external static pressure. For wet coil, subtract .1" external static pressure.
- 4) See unit nameplate or installation instructions for maximum recommended external static pressure.

# SYSTEM COOLING & HEATING CAPACITIES

## B5BX Cooling Capacities 50HZ (MBTUH)

Coil Refrigerant Temperature		35 °F			40 °F			45 °F			50 °F			55 °F			
		Evaporator Air- ENTERING DRY BULB/ WET BULB TEMPERATURE °F															
MODEL	CFM	80/67	76/63	72/59	80/67	76/63	72/59	80/67	76/63	72/59	80/67	76/63	72/59	80/67	76/63	72/59	
1.5/2.0	800	TC	36.36	31.10	25.89	33.81	25.66	19.28	26.53	22.24	17.20	18.68	17.38	12.55	16.55	10.94	11.56
		SC	22.03	21.40	20.55	19.14	19.47	18.39	18.49	17.91	16.75	14.82	18.72	12.55	15.66	10.94	11.56
	670	TC	32.56	27.81	23.14	29.68	22.91	17.36	23.51	19.48	15.54	16.81	15.04	11.07	14.31	9.80	9.69
		SC	19.49	18.79	18.10	16.78	16.79	15.71	15.66	15.53	14.83	12.50	15.78	11.07	13.88	9.80	9.69
	540	TC	28.76	24.52	20.38	24.53	19.14	14.42	19.48	16.05	13.53	13.92	12.03	8.91	11.40	7.98	7.48
		SC	16.96	16.18	15.66	13.74	13.44	12.02	11.81	13.15	12.23	9.18	12.17	8.91	12.10	7.98	7.48
2.5/3.0	1250	TC	62.44	52.98	43.88	53.80	44.28	34.67	44.51	34.34	26.00	34.05	24.88	19.87	23.49	19.13	13.89
		SC	39.11	37.97	36.08	36.08	34.31	31.61	32.54	30.07	25.93	28.79	24.63	19.47	23.46	19.13	13.89
	1100	TC	61.11	51.82	42.76	52.67	43.14	33.69	43.30	33.67	25.29	32.93	24.24	19.49	22.90	18.48	13.62
		SC	38.07	36.98	35.01	35.11	33.39	30.74	31.76	29.23	25.20	27.71	23.99	19.09	22.81	18.48	13.62
	830	TC	57.93	49.06	40.28	49.84	40.63	31.58	40.56	31.45	23.67	30.90	22.75	18.46	21.49	17.09	12.91
		SC	35.62	34.61	32.64	32.90	31.29	28.72	29.81	27.27	23.55	25.76	22.50	18.06	21.30	17.09	12.91
3.5/4.0	1800	TC	77.75	66.60	55.71	68.01	56.49	44.96	56.88	44.91	34.28	44.71	32.94	26.73	31.54	25.23	19.51
		SC	48.56	47.47	45.83	45.08	43.66	40.76	41.58	39.03	34.09	37.24	32.52	26.73	31.02	25.23	19.51
	1480	TC	82.96	70.97	59.54	72.54	60.26	47.98	60.65	48.07	36.54	47.59	35.25	28.66	33.55	26.98	20.77
		SC	52.16	51.28	49.68	48.64	47.41	44.14	44.85	42.54	36.52	40.55	34.97	28.66	33.18	26.98	20.77
	1310	TC	76.28	65.09	54.15	66.47	54.70	43.78	55.35	43.58	33.38	43.10	31.89	25.82	30.37	24.35	18.75
		SC	47.62	46.42	44.43	44.17	42.30	39.82	40.31	38.04	33.00	36.08	31.55	25.82	29.95	24.35	18.75
5.0	2200	TC	89.88	76.34	63.29	74.43	61.69	52.02	64.89	51.77	38.20	49.74	36.93	37.97	36.30	31.10	22.62
		SC	56.05	54.52	50.85	51.91	51.11	49.01	48.44	46.19	41.18	44.24	37.59	33.13	35.70	31.10	22.62
	1980	TC	84.09	71.68	59.53	70.34	58.26	48.66	60.46	47.87	35.75	47.16	34.55	34.45	33.74	28.65	20.98
		SC	51.92	50.63	47.74	48.59	48.01	45.26	45.37	42.19	38.07	41.24	34.98	30.53	33.12	28.65	20.98
	1720	TC	76.99	65.67	54.46	64.88	53.58	44.32	55.24	43.27	32.60	42.87	31.48	30.29	30.60	25.64	18.94
		SC	47.03	46.03	43.32	44.04	43.22	40.58	40.87	37.45	34.28	36.56	31.66	27.34	29.96	25.64	18.94



279C-0506